



4012TESI HC

Spark Ignited Gas Engine

Electrounit Technical Data

Basic Technical Data

Number of cylinders: 12
Cylinder arrangement: 60°Vee
Cycle: 4 stroke, spark ignition.
Induction system: Turbocharged.
Bore: 160mm.
Stroke: 190mm.
Compression ratio: 11.5:1.
Cubic capacity: 45.842 litres.
Direction of rotation: Anti-clockwise viewed on flywheel.
Firing order: 1^A,6^B,5^A,2^B,3^A,4^B,6^A,1^B,2^A,5^B,4^A,3^B
 Cylinders 1 furthest from the flywheel.
 Cylinders designated A are on the left side of the engine when viewed from front (opposite end to flywheel) and cylinders designated B are on the right side of the engine.
Total weight (dry): Engine only 4680kg.
Total weight (wet): Engine only 4908kg.

Moment of Inertia: Engine 6.04kg m²; Flywheel 9.10 kg m².

Cyclic Irregularity for engine and flywheel prime power	1200 rev/min	1500 rev/min
	—	1.725

RATINGS are as defined in ISO3046/1 (BS5514/1 - 1982)
 Electrical ratings are based on average alternator efficiency and are for guidance only (0.8 Power Factor being used).

For Load Acceptance Figures, please refer to Stafford Applications Engineering Department.

General installation data

Engine speed	Units	Continuous Baseload rating	
		1200	1500
		50Hz	
Designation		90	140
Gross engine power	kW	632	632
BMEP gross	bar	11.0	11.0
Combustion airflow	m ³ /min	56.4	59.4
Exhaust gas temperature max (after turbo)	°C	397	406
Exhaust gas flow (max)	m ³ /min	131.3	130.1
Boost pressure ratio (max)	-	2.30	2.20
Overall electrical efficiency	%	34.3	34.8
Piston speed	m/s	9.5	9.5
Charge coolant flow	l/s	10.0	10.0
Nominal excess air factor (Lambda)	λ	1.79	1.77
Typical Gen Set 25°C (100 kPa)			
Electrical Output 0.8pf	kW	600	600
Assumed alternator efficiency	%	95	95

Continuous Baseload rating Power available for continuous full load operation. No overload available.

Operation Point

Engine speed: 1500 rpm
Ignition timing: 27 BTDC(90)
Ignition timing: 28 BTDC(140)
Mixture cooler water temperature: 75°C
Cooling water exit temperature: <96°C
Exhaust emission: according to 1^{1/2} x TA_Luft (NOx) (90)
 according to TA-Luft (140)

Fuel data natural gas (UK)

Lower calorific value: 34,710 KJ/Sm³ (45,671 KJ/kg)
Density: 0.76 kg/Sm³
Stoich. air requirement: 16 kg/kg
Minimum methane number: 80

Performance

Steady state speed stability at constant load: ± 0.25%.
Note: All data based on operation to ISO 3046/1, BS 5514 and DIN 6271 standard reference conditions.
Test conditions: Air temperature 25°C, barometric pressure 100kPa, relative humidity 30%.

Derating from ISO 3046 Standard Conditions for speed build 1500 rev/min.

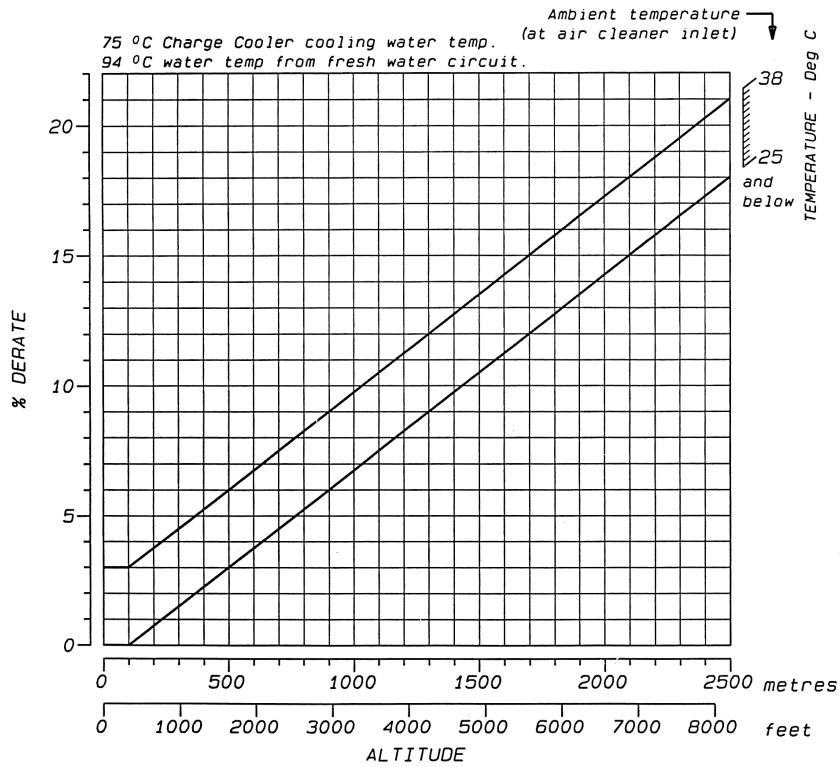

For engines above 2,500 m consult Perkins Engines Company Ltd. No derating required for humidity at any altitude or temperature.

Derating from ISO 3046 Standard Conditions for speed build 1500 rev/min.

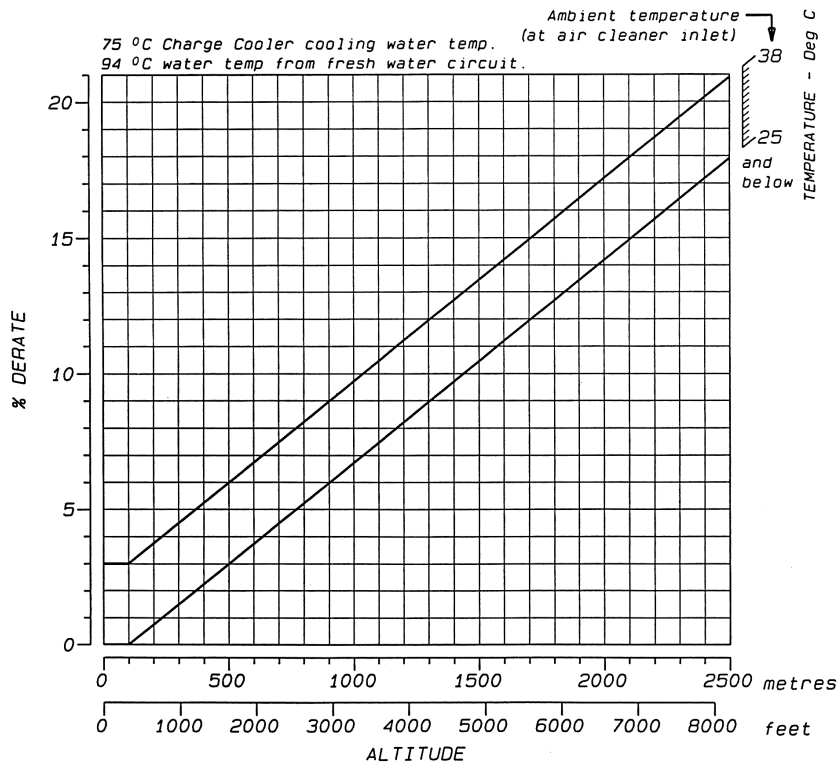

For engines above 2,500 m consult Perkins Engines Company Ltd. No derating required for humidity at any altitude or temperature.

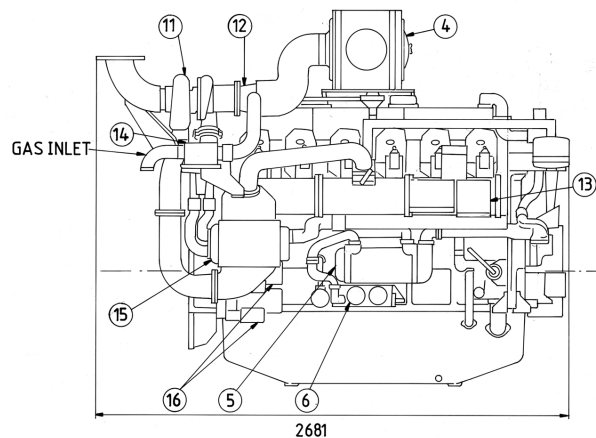
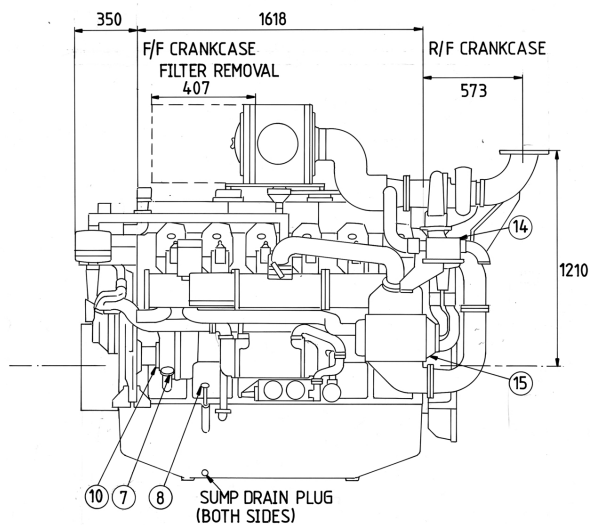

THIS DRAWING COVERS GENERAL DIMENSIONS ONLY. FOR INSTALLATION DETAILS G-A- DRAWINGS MUST BE OBTAINED FROM PERKINS ENGINES COMPANY LTD

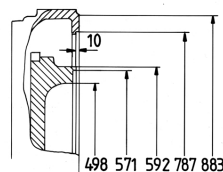

SAE 00 FLYWHEEL HOUSING
SAE 518 FLYWHEEL

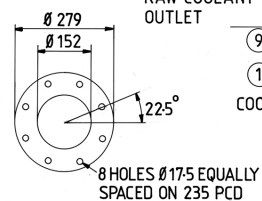
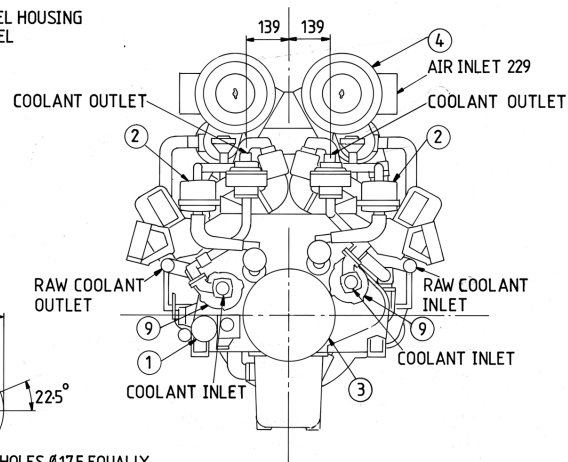
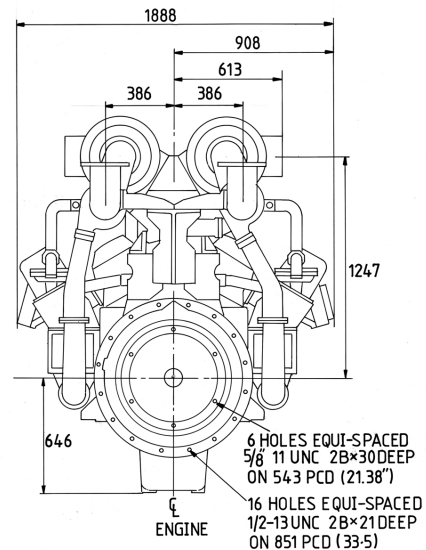

EXHAUST FLANGE
BS10 TABLE D

4012 TESI GAS ENGINE

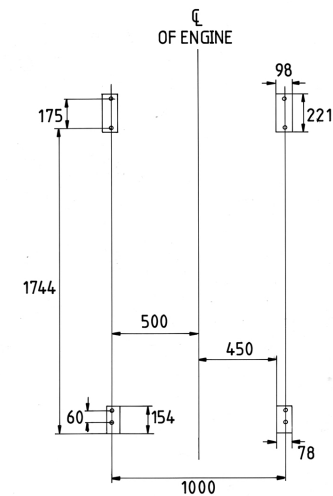

ITEM	
1	ALTERNATOR (BATTERY CH'G)
2	BREATHERS
3	T/V DAMPER (WITH GUARD)
4	AIR CLEANER
5	OIL COOLER
6	OIL FILTERS
7	OIL FILLER
8	DIPSTICK
9	COOLANT PUMP
10	RAW COOLANT PUMP
11	TURBOCHARGER
12	CARBURETTOR
13	IGNITION CONTROL BOX
14	GAS REGULATOR
15	CHARGE COOLER
16	24v STARTER

THE CENTRE OF GRAVITY OF THE ENGINE IS LOCATED ON THE VERTICAL CENTRE LINE WHICH IS 38mm ABOVE THE CRANKSHAFT HORIZONTAL CENTRE LINE. IN THE OTHER VIEW IT IS 771mm FROM THE CRANKCASE REAR FACE.

ENERGY BALANCE CONTINUOUS Baseload rating	Units	1200		1500	%	1500	%
		rev/min.		rev/min.		rev/min.	
Energy in fuel (Fuel heat of combustion)	kW	-		1750	100	1725	100
Energy in power output (Net) (Engine shaft power)	kW	-		632	36.1	632	36.6
Energy to exhaust	kW	-		459	26.2	492	28.5
Energy to coolant and oil (jacket cooling water and lub oil)	kW	-		506	28.9	458	26.5
Energy to charge coolers (mixture cooler)	kW	-		83	4.7	85	4.9
Sum of usable heat	kW	-		930	53.1	886	51.3
Sum of usable energy	kW	-		1562	89.2	1518	88
Energy to radiation (surface radiation and other losses)	kW	-		70	4.1	63	5.4

NB Not to be used for CHP design purposes. (Indicative figures only). Consult Perkins Engines Co. Ltd. Assumes complete combustion.

Cooling System

Recommended coolant: 50% inhibited ethylene glycol or 50% inhibited propylene glycol and 50% clean fresh water. For combined heat and power systems and where there is no likelihood of ambient temperature below 10°C, then clean 'soft' water may be used, treated with 1% by volume of Perkins inhibitor in the cooling system. The inhibitor is available in bottles under Perkins Part No. OE 45350 (1 litre).

The following is a guide based on ambient air conditions of 52°C.

Total coolant capacity (engine only): 73 Litres
Maximum jacket water pressure in crankcase: 1 bar (plus static pressure head)

Jacket cooling water data	Units	1200	1500
		rev/min	rev/min
Coolant flow	m ³ /h	-	55
Coolant exit temperature (max)	°C	-	96
Coolant entry temperature (max)	°C	-	88

Charge cooling water data	Units	1200	1500
		rev/min	rev/min
Coolant flow	m ³ /h	-	36
Coolant entry temperature (max)	°C	-	75

Charge cooler: Fin and tube on engine separate to radiator
Coolant pump: Gear driven

Maximum static pressure head on pump above engine crank centre line: 7m

Maximum external permissible restriction to coolant pump flow: 0.3 bar

Thermostat operating range: 71-85°C

Shutdown switch setting: coolant 96°C rising.

Coolant immersion heater capacity: 4kW 2 off

Lubrication System

Recommended lubricating oil: Lubricating oil requirements vary with fuel used. Full specifications including oil sampling recommendations and condemnation limits appear on the Fuel, Coolant and Lubricating Oil Recommendation Sheet for the 4000 Series Gas Engines.

Lubricating oil capacity:

Total system: 178 litres.

Sump maximum: 159 litres.

Sump minimum: 136 litres.

Lubricating oil temperature Maximum to bearings: 105°C

Lubricating oil pressure at 85°C temperature to bearings: 0.34 MPa

Designation	90		140	
	1200	1500	1200	1500
Oil consumption (continuous rating)				
New engine †	l/hr	- 0.54	-	0.54
After RUNNING-IN ††	l/hr	- 0.27	-	0.27
Oil flow rate from oil pump	l/s	- 6.00	-	6.00

† after commissioning. †† typical 250 hours

Sump drain plug tapping size: G1

Oil pump: Gear driven

Shutdown switch setting: oil 1.93 bar falling

Normal operating angles: Fore and aft: 5°
Side tilt: 22.5°

Fuel System

Recommended fuel: Natural Gas LHV at 34MJ/m³ (930 Btu/cu.ft.)

Other fuels may be used: e.g. Landfill. Digester gas. Ratings will vary from those shown.

Where fuels other than Natural Gas are being considered it is imperative that a full gas analysis (including details of any solid or liquid components) be obtained. Reference should then be made to Perkins Engines Company Ltd. to determine its suitability.

Gas supplies must be filtered to the same standard as the engine intake air, i.e. Maximum particle size not to exceed 5 micron.

Gas supply pressure: 1.5 kPa (153mmH₂O) - 4.9 kPa (500 mmH₂O) at full rated flow conditions.

Carburettor type: Deltec with zero pressure regulator.

Installation of gas supply and shut off valves to be in accordance with local regulations.

Fuel consumption gross	kJ/kWs			
	90		140	
Designation	1200	1500	1200	1500
rev/min				
At CONTINUOUS Baseload rating	-	2.77	-	2.73
At 75% of Prime Power rating	-	2.90	-	2.80
At 50% of Prime Power rating	-	3.04	-	2.99
At 25% of Prime Power rating	-	3.76	-	3.67

Fuel: Natural Gas - LHV = 34.71 MJ/m³

Tolerance on Fuel consumption +5%

Designation	90		140	
	Units	1500	1500	1500
Mass flow data				
Fuel	kg/h	138		136

Designation	90		140	
	Units	1500	1500	1500
Volume flow data (100 kPa)				
Fuel (15°C)	Sm ³ /h	181.6		178.9

Induction System

Maximum air intake restriction of engine:

Dirty filter: 380 mm H₂O.

Air filter type: 2 off Dry type

EXHAUST EMISSIONS DATA

Ambient temperature of 25°C

Emissions at continuous baseload rating

If the engine is to operate in ambient conditions other than test conditions then suitable adjustments may be necessary for any change in inlet air temperature or barometric pressure.

Designation	90		140	
	1200	1500	1200	1500
rev/min	1200	1500	1200	1500
Oxygen (O ₂) %	-	9.76	-	9.60
*Oxides of Nitrogen (NOx) mg/Nm ³	-	249	-	400
*Hydrocarbons (HC) kg/h	-	3	-	3
*Carbon Monoxide (CO) mg/Nm ³	-	748	-	612

*Corrected to 5% O₂

Designation		90	140
Mass flow data	Units	1500	1500
Combustion air	kg/h	3959	3852

Designation		90	140
Volume flow data (100kPa)	Units	1500	1500
Combustion air (25°C)	m ³ /h	3386	3295

Exhaust System

Designation	90		140		
	Units	1200	1500	1200	1500
Maximum back pressure for total system	mmH ₂ O	-	408	-	543

Exhaust Outlet flange size: 2 x 152mm (Table 'D')

Recommended pipe size: Refer to Installation Manual.

Designation	90		140	
	Units	1500	1500	1500
Mass flow data	Units	1500	1500	1500
Exhaust gas (wet)	kg/h	4097	3988	

Designation	90		140	
	Units	1500	1500	1500
Volume flow data (100 kPa)	Units	1500	1500	1500
Exhaust gas (at turbo exit temp)	m ³ /h	7910	7805	

Designation	90		140	
	Units	1500	1500	1500
Exhaust data	Units	1500	1500	1500
Exhaust temperature	°C	397	406	
Oxygen content in exhaust gas	%	9.76	9.60	
Lambda	λ	1.79	1.77	

Starting Requirements

TEMPERATURE RANGE	
Down to 0°C (32°F)	<p>Oil: See page 4</p> <p>Starter: 24 Volts 2 off Battery: 4x12Volts Total Ah 143 Inrush current to starter: 286 1,000 amps. Cranking current: 600 amps. Starter Cable size: 120mm Maximum length: 6m</p>

NOTES: 1. Battery capacity is defined by the 20 hour rate.

- The starting ability of an engine with immersion heater will be improved by about 10°C and the start aid specification can be modified accordingly. The oil specification should be for the minimum ambient temperature as the oil will not be warmed by the immersion heater.
- Breakaway current is dependent on battery capacity available. Cables should be capable of handling the transient current which may be up to double the steady cranking current.

Electrical System

Type: Insulated return.

Alternator: 24 volts with integral regulator.

Alternator output: 32 amps at stabilised output 28 volts at 20°C ambient.

Starter motor: 24 volts

Starter motor power: 16.4 kW.

Number of teeth on flywheel: 156

Number of teeth on starter motor: 12

Minimum cranking speed: 120 rev/min.

Pull in current of starter motor solenoid: 26.8 amps at 24 volts.

Hold in current of starter motor solenoid: 9 amps at 24 volts.

Ignition System

Primary system type: Altronic Disn

Primary voltage: 24 volts

Polarity: Negative earth

Ignition coils: 1 per cylinder, type - Altronic 501010

Spark plug type: Champion RB77WPC or equivalent

Spark plug gap: 0.40mm

Spark plug leads: 12mm silicon spark plug cable

Ignition timing: 27 deg BTDC (90) 28 deg BTDC (140)

Governor type: Heinzman Electronic

NOISE LEVELS: The figures for total noise levels are typical for an engine running at the prime power rating in a semi-reverberant environment and measured at a distance of one metre from the periphery of the engine.
OCTAVE ANALYSIS: The following histograms show an octave band analysis at the position of maximum noise level.

TOTAL NOISE LEVEL (Sound pressure level re: -20×10^{-6} pa)
 Speeds 1500 r/min
 Ambient noise level 75 dBA

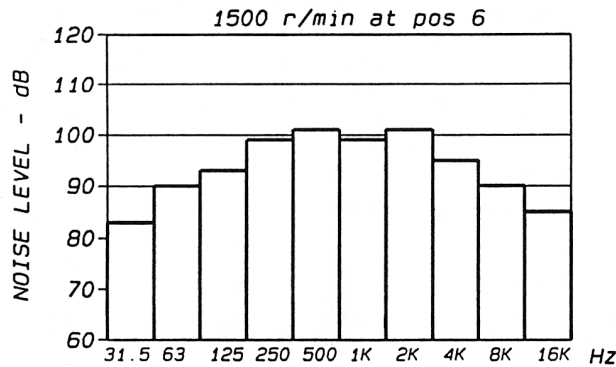
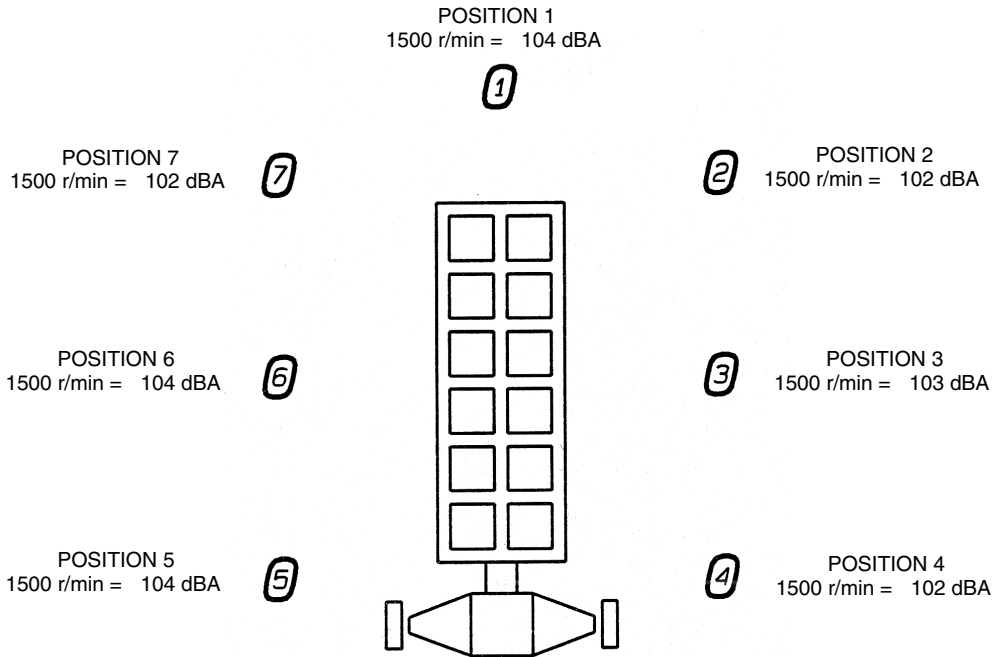

Engine Mounting

Maximum additional load applied to flywheel due to all rotating components 850 kg.



Perkins Engines Company Ltd.

Tixall Road, Stafford, ST16 3UB. Telephone: +44 (0)1785 223141 Facsimile: +44 (0)1785 215110